

x1

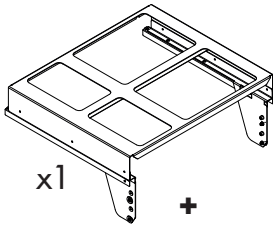

x1



x2



x2

M6x12 mm



x4

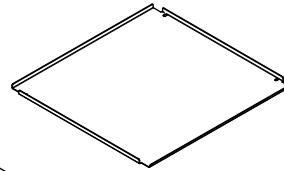

x1



x4

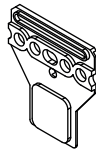

x4

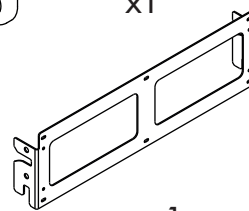

x1

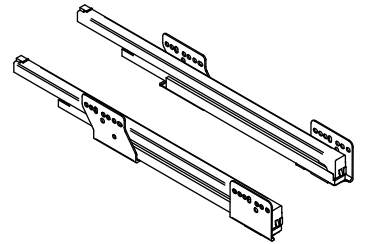

x1

ø4x16 mm ø4x16 mm



x10



x4

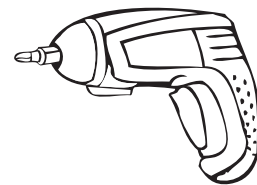
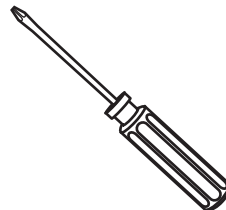
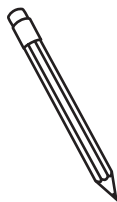
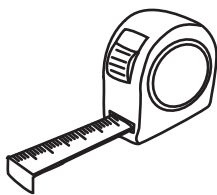

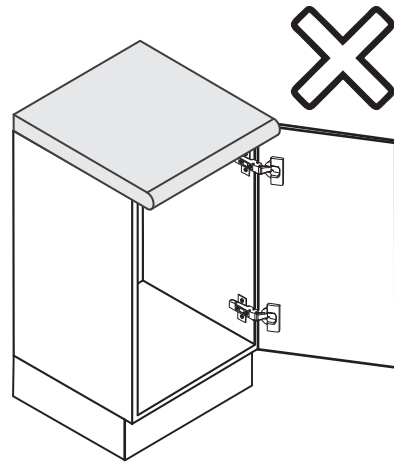
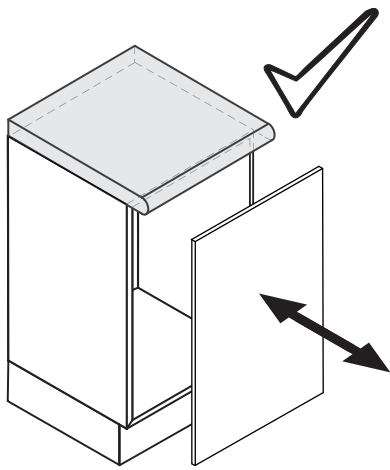

1

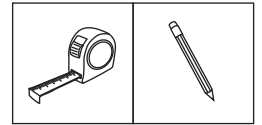
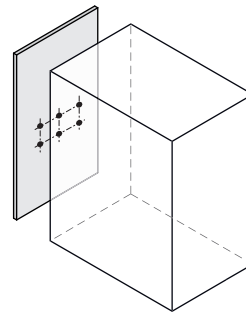
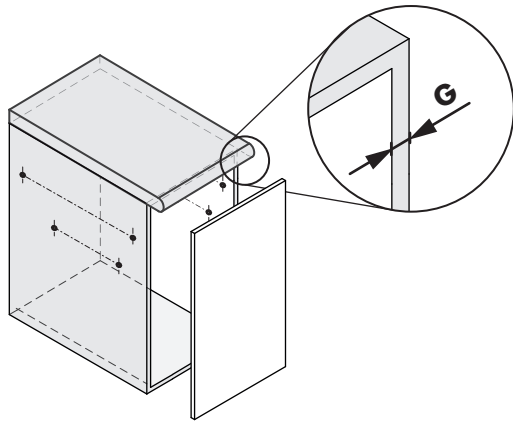

G X Y

16	347	204
19	347	207

P Z

450	165
500	190
600	240

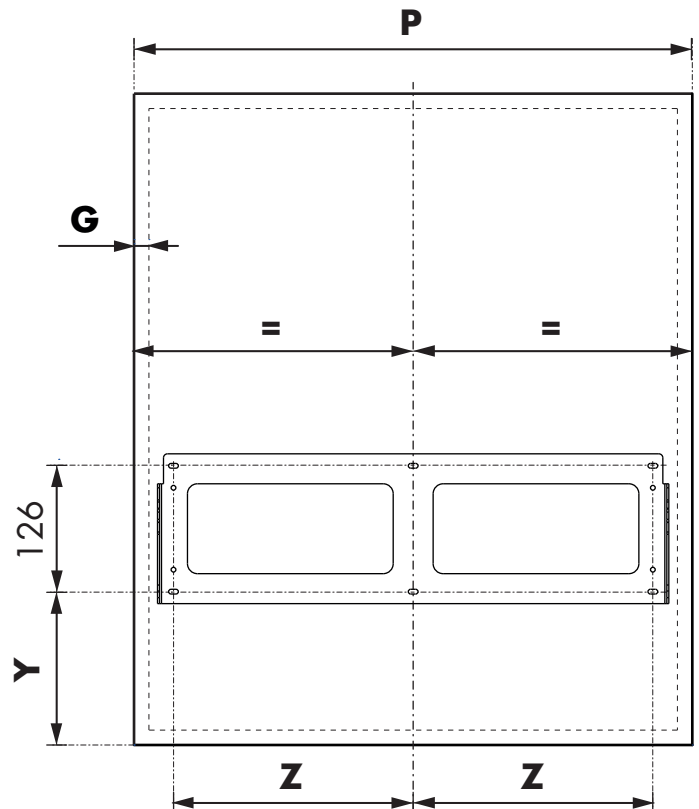
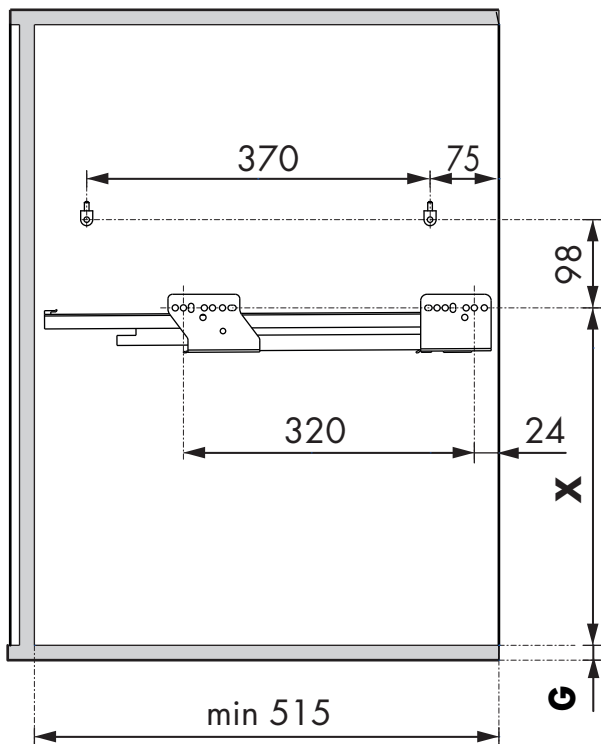

Unidades en milímetros | Units in millimeters | Unités en millimètres

2.1

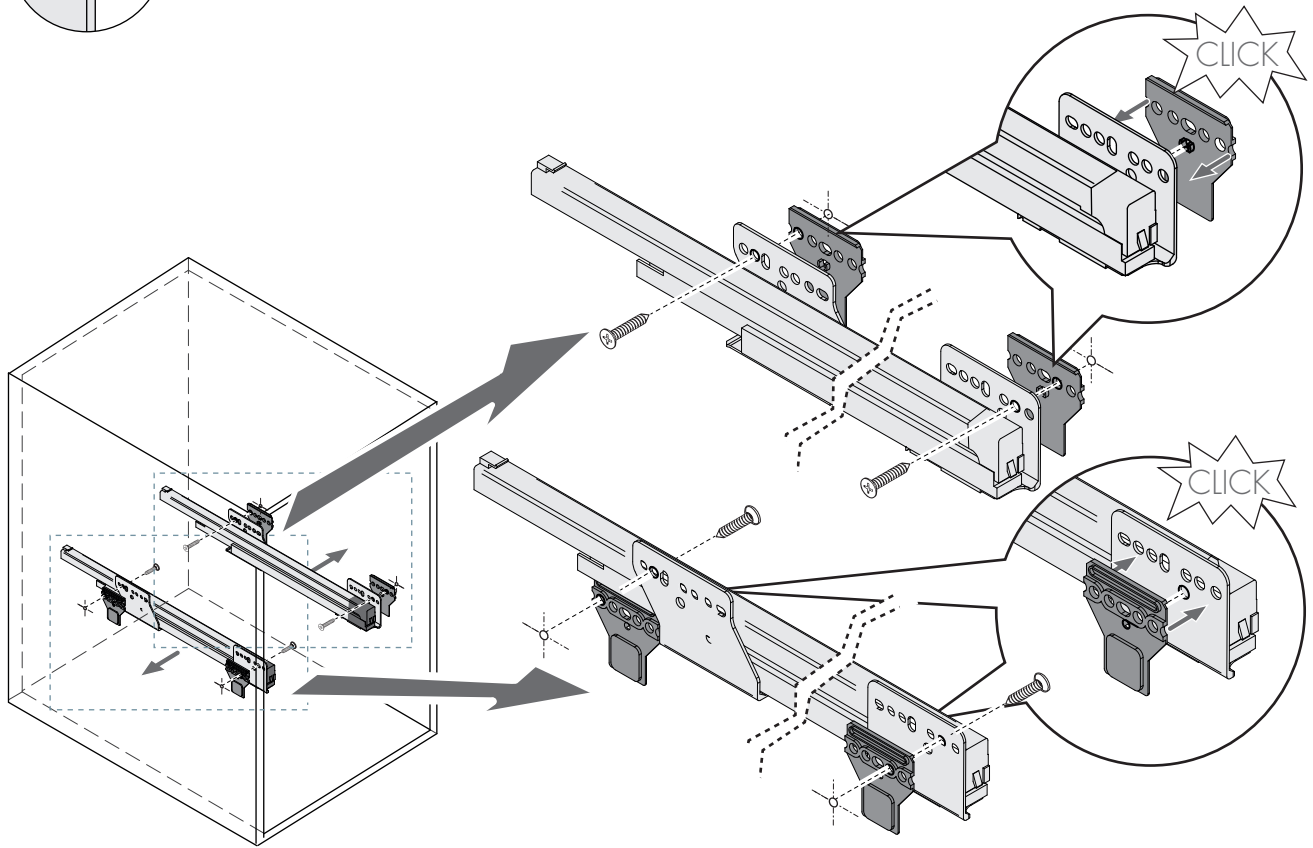
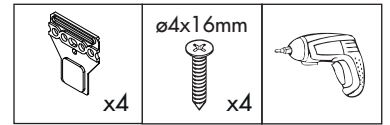
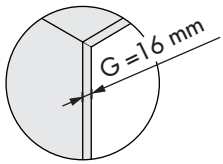

2.2

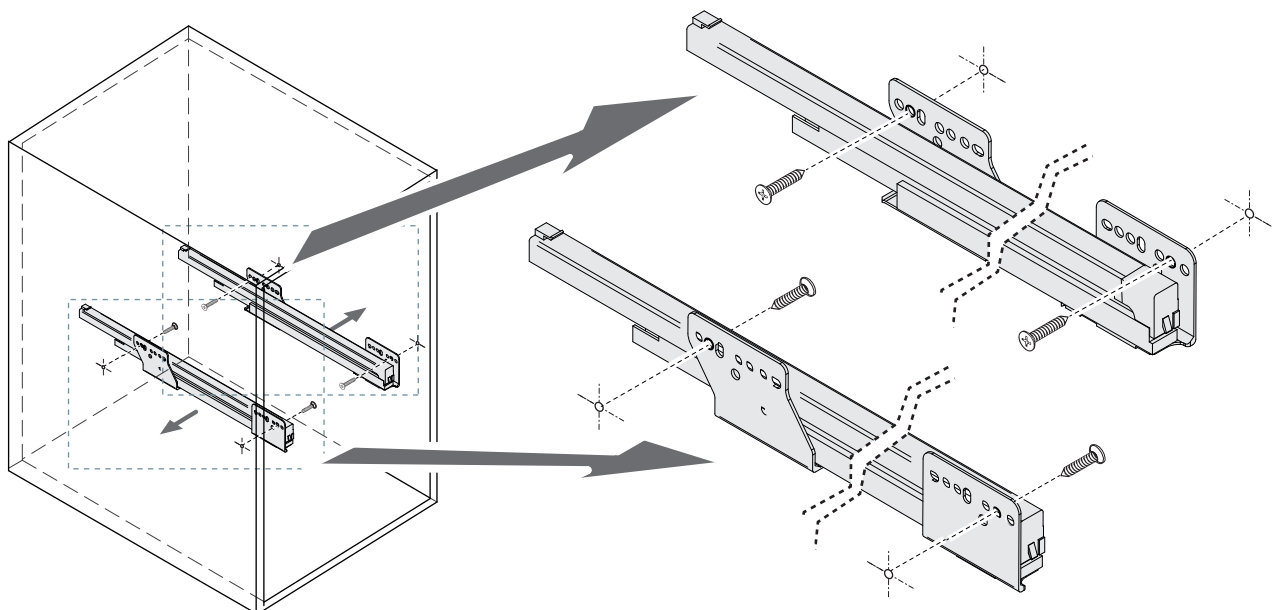
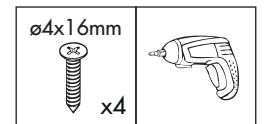
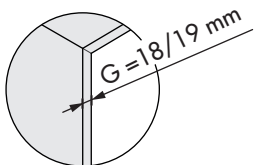

3

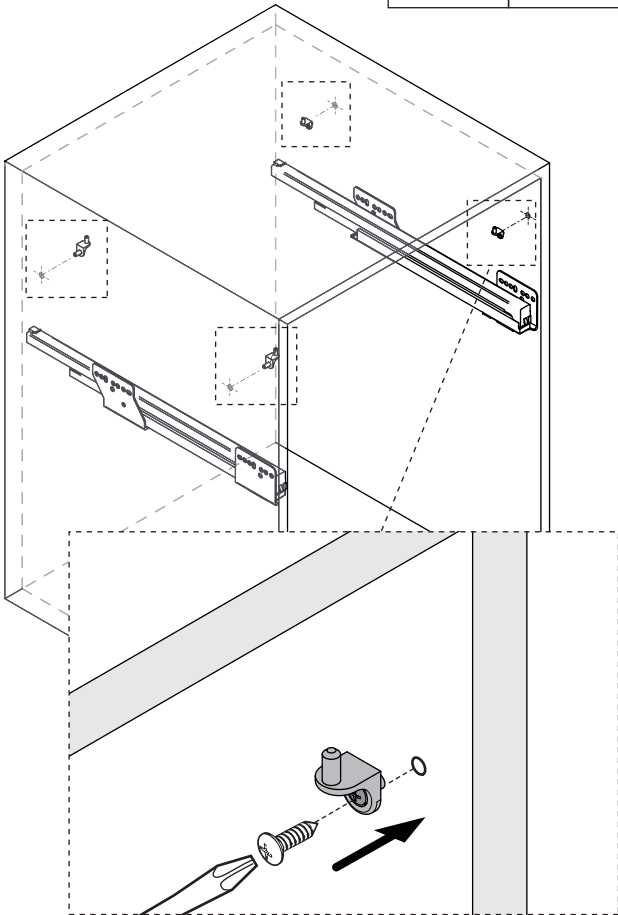
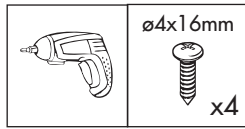

4

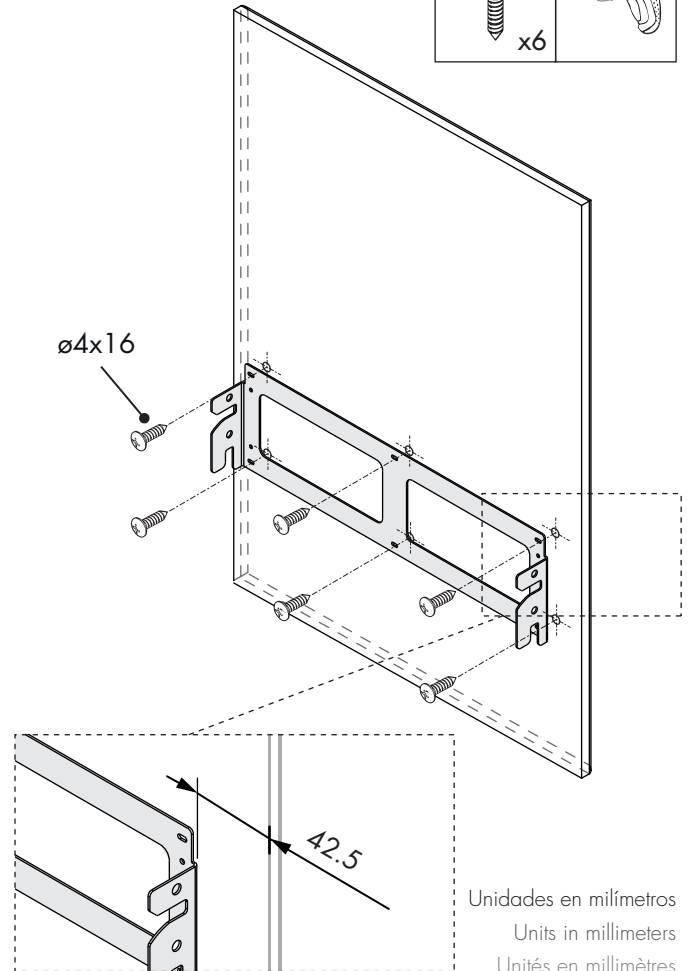
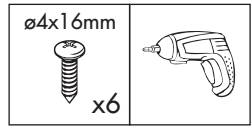

5

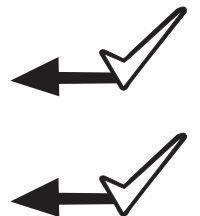
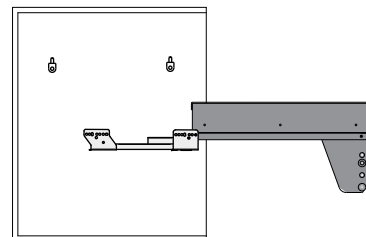
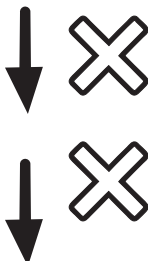
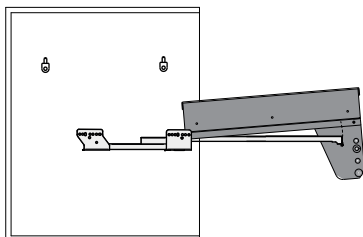
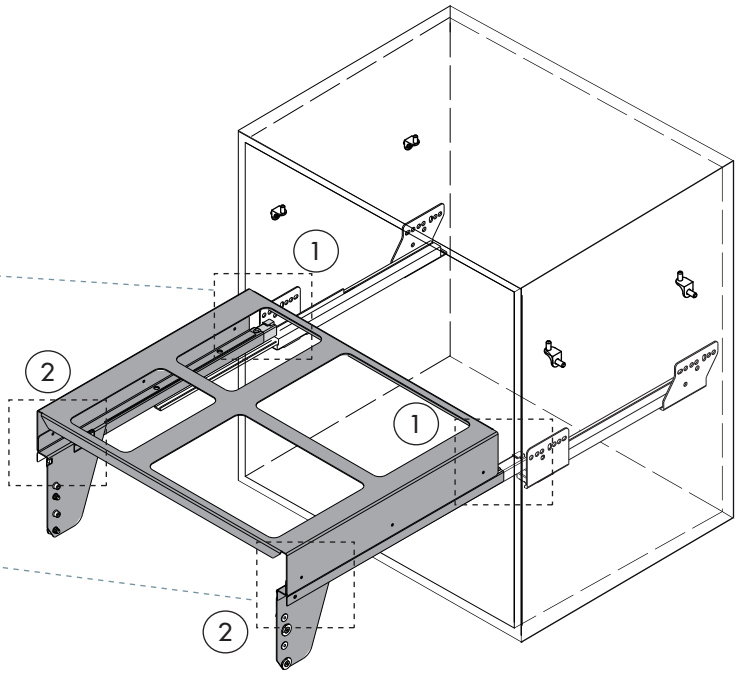
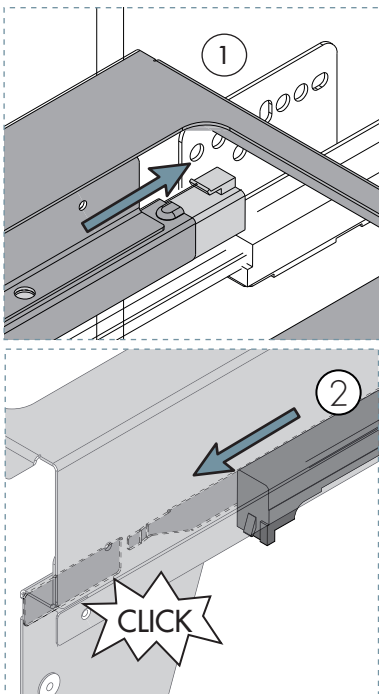

6

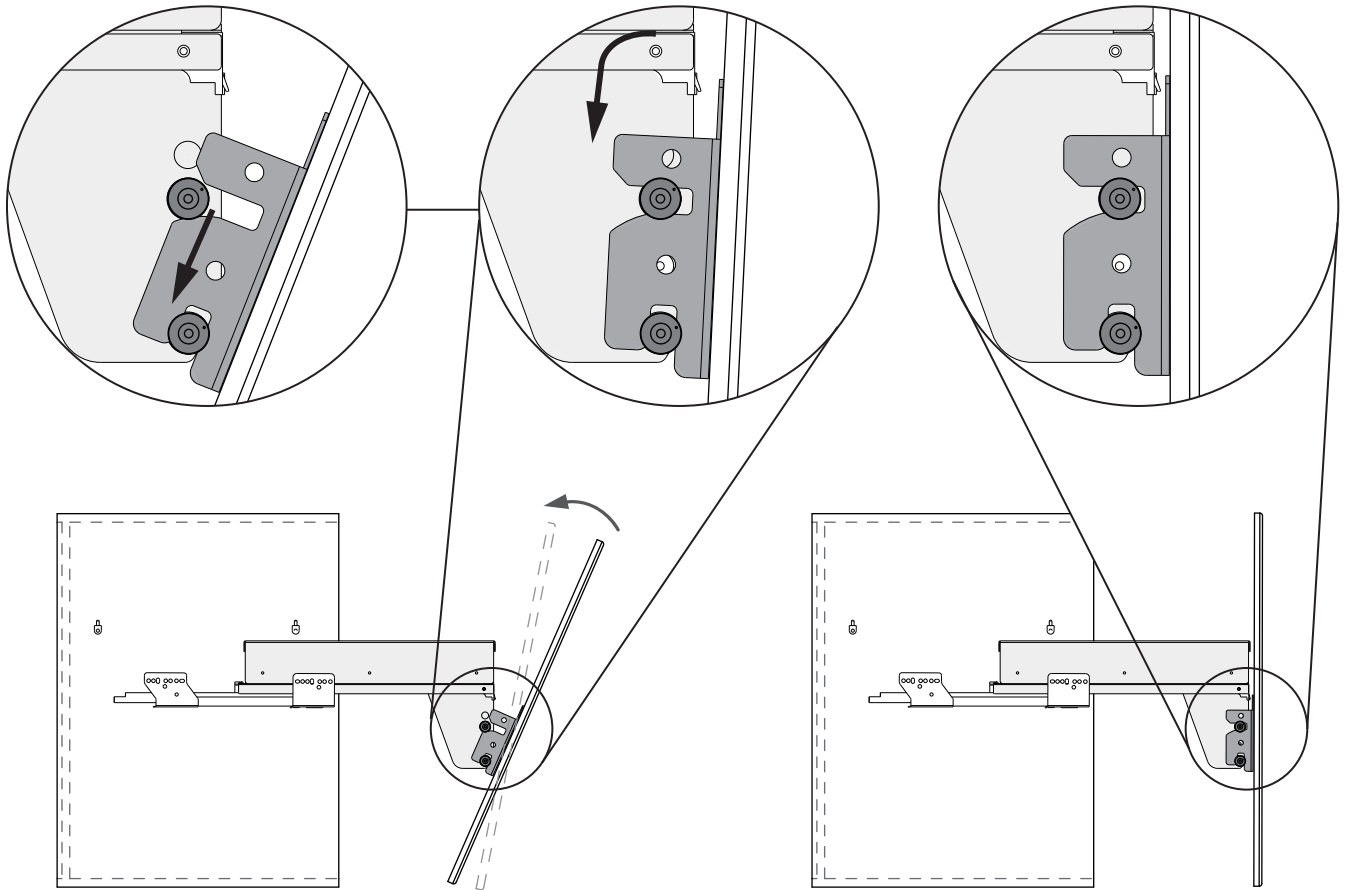

7

M6x12mm
x4

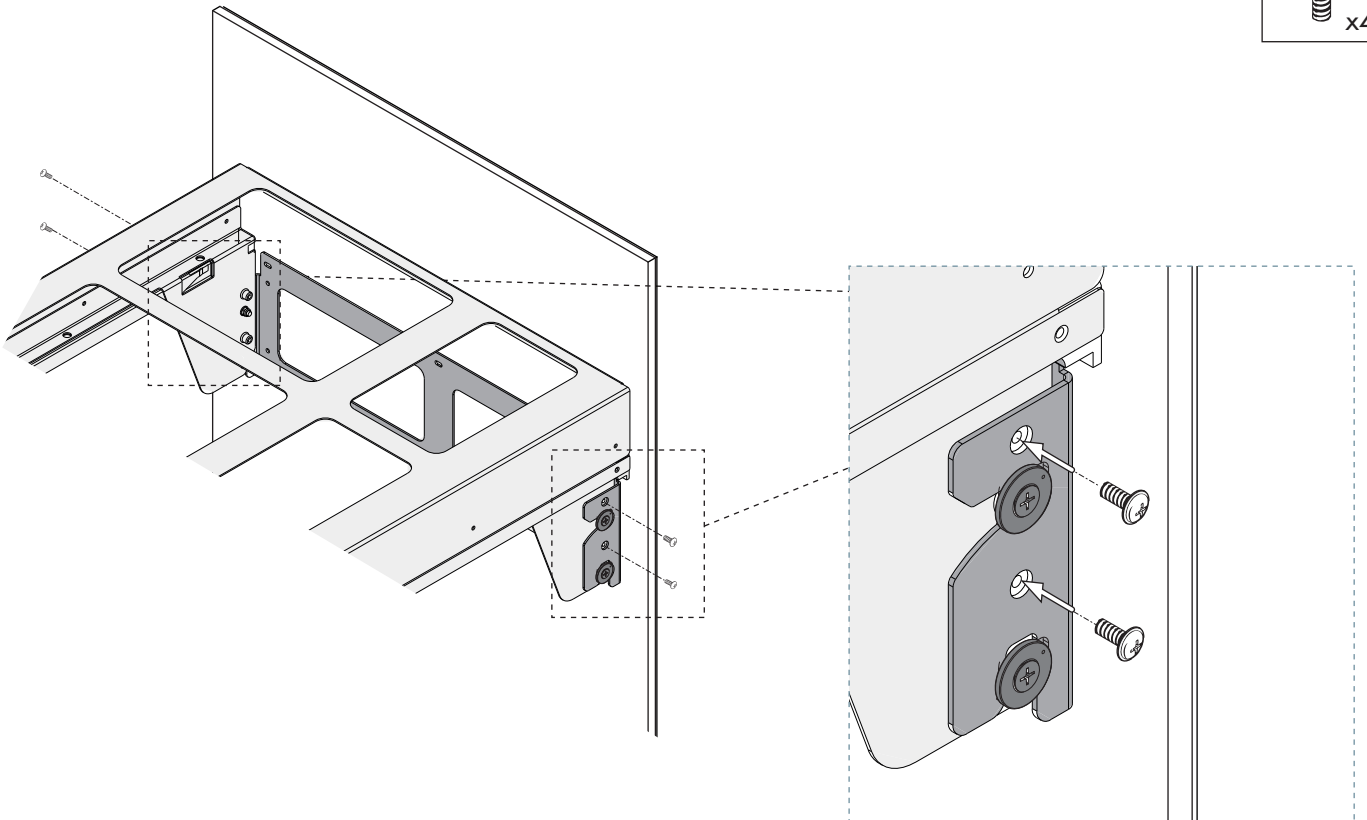

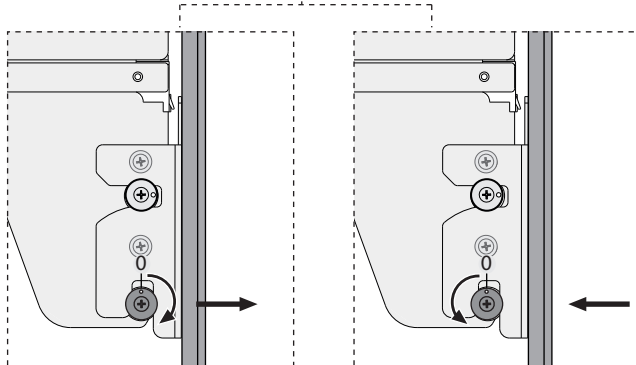
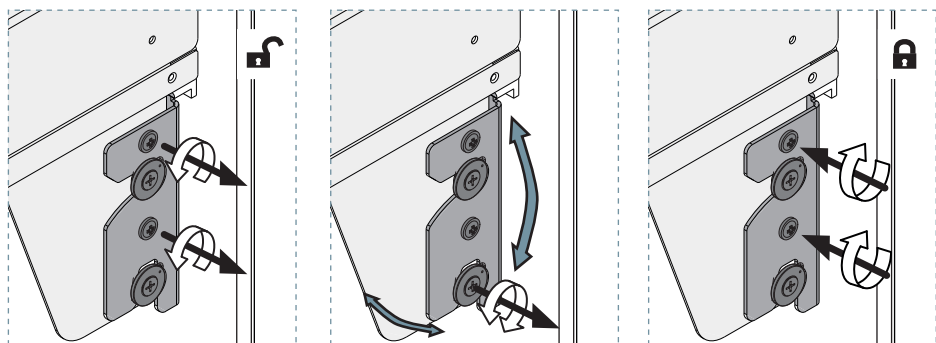
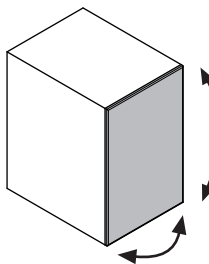
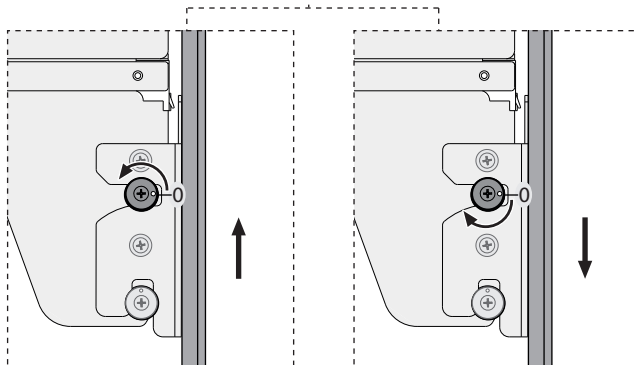
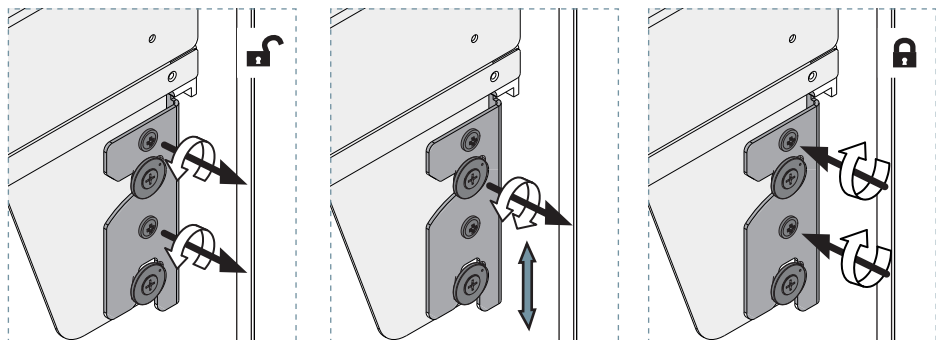
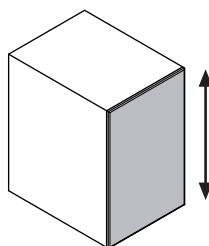
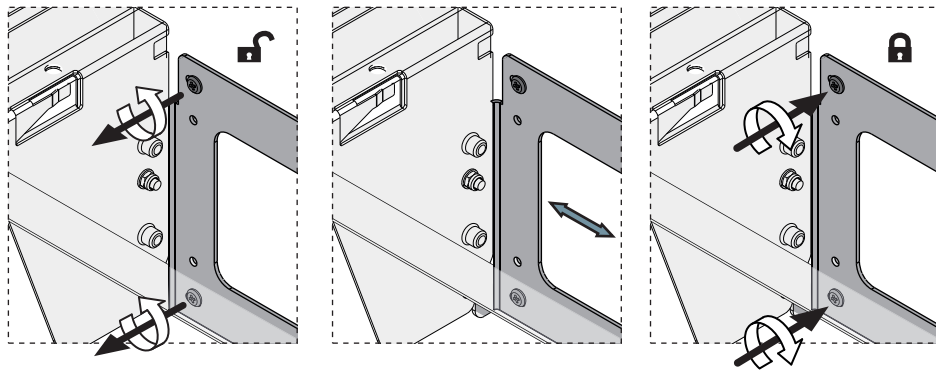
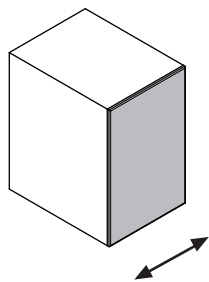

9

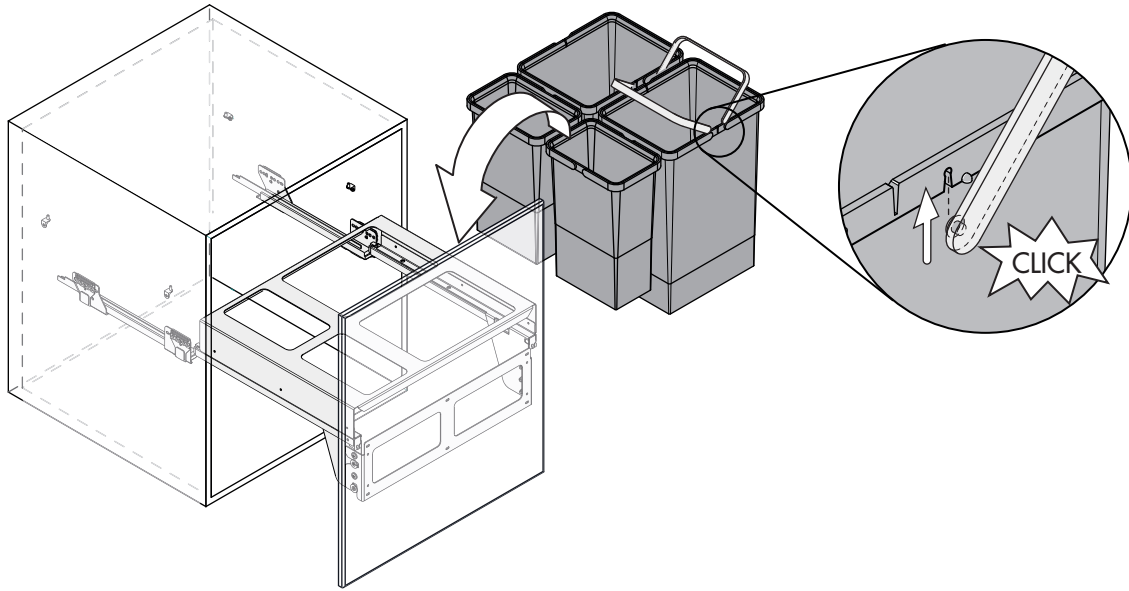

10

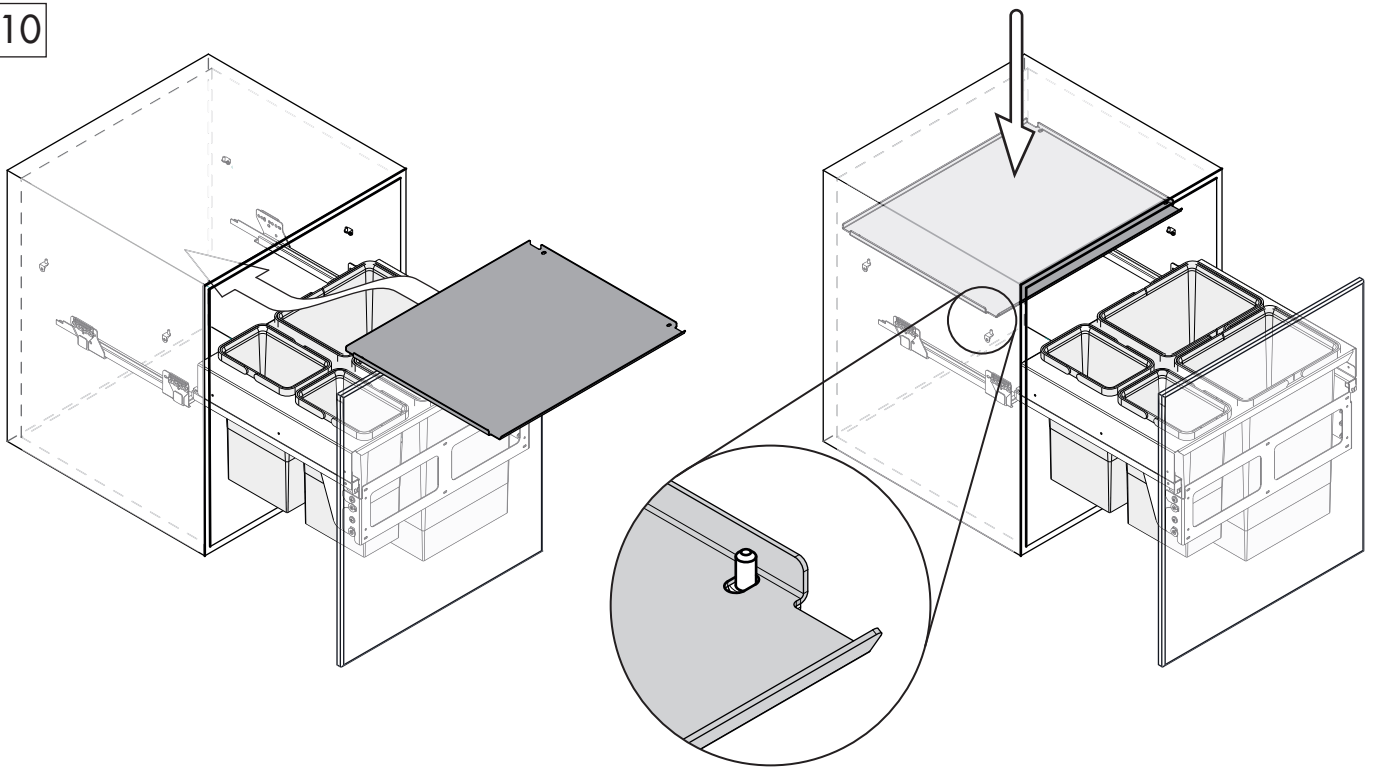

11 Desmontaje | Disassembly

